

hanström

Tap into the future.

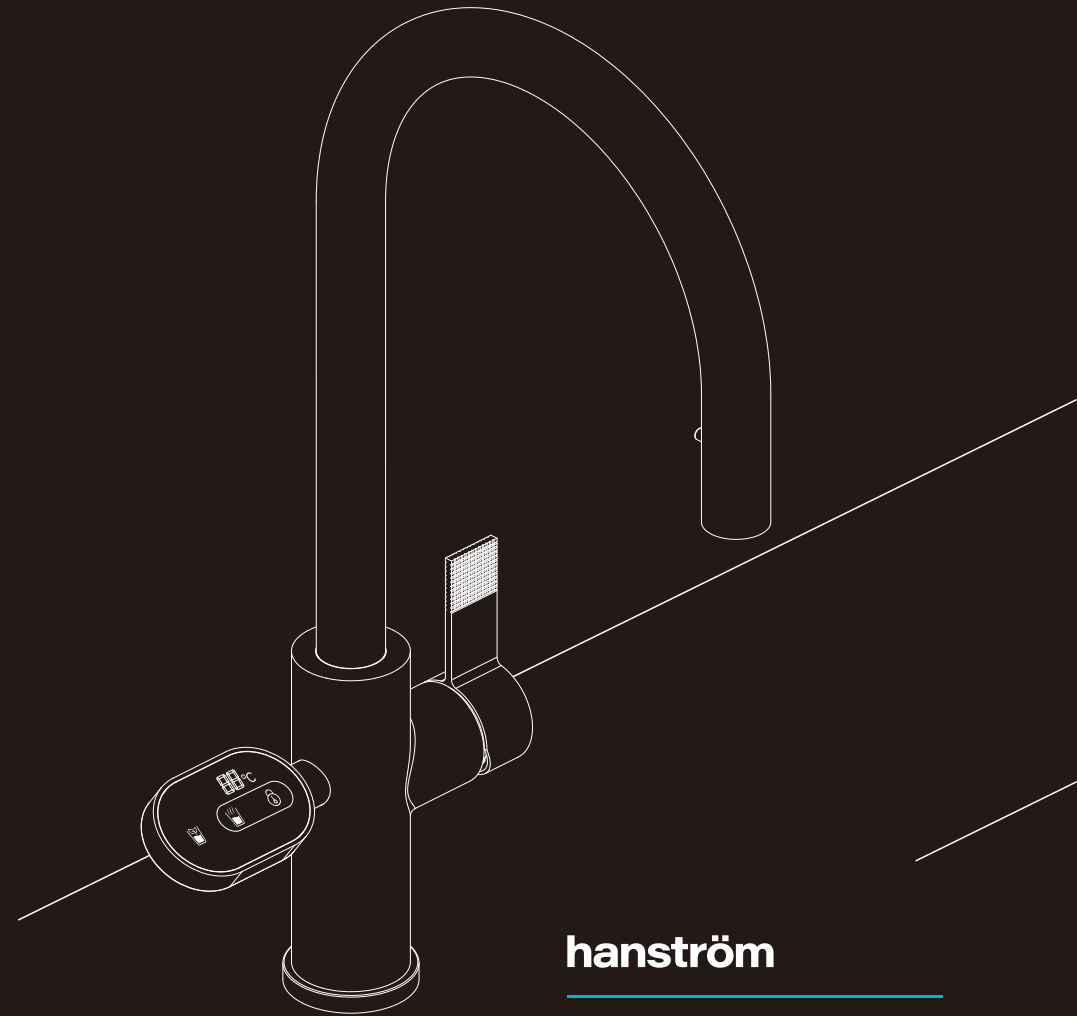

hanström

4-in-1 Boiling Water Tap

Installation Manual

Safety Instructions - Please Read



Alert symbols identify important safety information to make you aware of potential hazards that can cause property damage or in the severest cases, serious injury or death.

This product is not for outdoor use!

A standard 220/240v grounded 13 amp switched electrical outlet is required under the sink for the appliance electrical power. Warranty will be immediately invalidated if an incorrect form of electrical socket or power is used.

The power outlet must be connected to the 13 amp fused plug supplied.

Do not plug in the tank until all water connections have been checked, watertight and the tank has been filled. The tank is filled once water starts to pass out the tap spout.

It is recommended before using the tank, to flush through several litres of water to remove any air in the system when installing.

Please note, that in order to avoid having pressurised boiling water and to comply with British standards, this is an open vented system. In order to ensure the instant hot water tank delivers the highest quality drinking water and is protected from limescale build up, the water filter must be replaced every 6 months. Failure to do so may invalidate your product warranty.

The instant hot water tank is only intended for use with compatible taps. Using this tank with any other tap will invalidate the warranty.

The instructions are only intended as a guide, if there is any doubt then please contact a certified tradesperson or your point of purchase and avoid using the appliance until it has been checked.

Safety Instructions - Continued



To prevent against electrical shock do not place the hot water tank near or in water or other liquids and install on a flat surface.

Do not install in environments above 35°C or exposed to freezing.

Can be used by children 12+ or people with learning difficulties if they have been given supervision or instructed on the hazards involved.

Do not operate or install electrical connections with wet hands.

Do not install the appliance if it appears damaged in any way.

Only use power lead supplied with the product. If the power lead is damaged, stop using immediately and contact customer services for a replacement.

Do not remove tank casing, this product is not serviceable and should be returned to the manufacturer in the event of a fault.

Do not modify the tank or remove the plug as this will invalidate the warranty and could cause serious injury. Design for 3 pin socket only.

If the unit is unused for extended periods of time it should be unplugged, drained, re-filtered and refilled.

The tank and water tank can be cleaned with a lint free damp cloth.

Do not use any abrasive or corrosive cleaning products as this will damage the surface of the product.

Replace the filter every 6 months.

Product size & Installation

Unit: mm

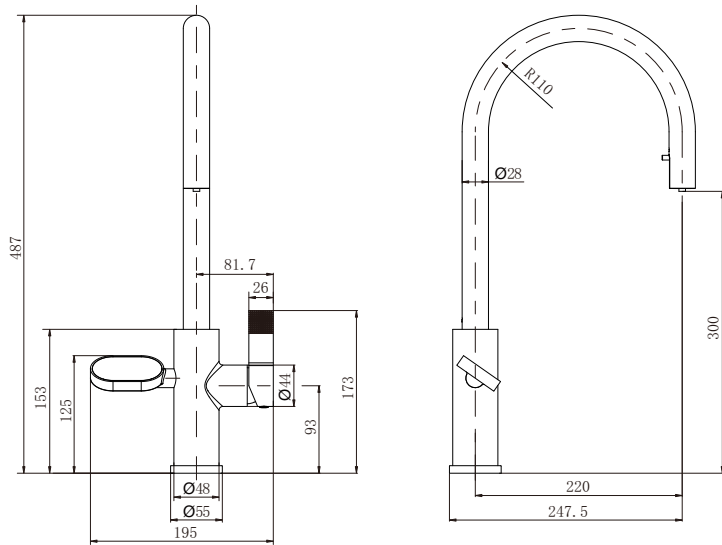

Installation Procedure

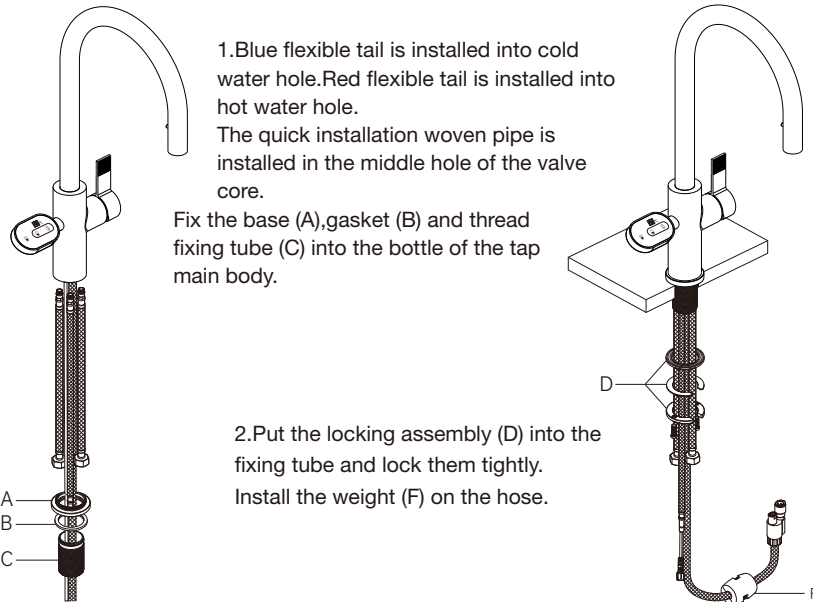

6

Installation - Continued

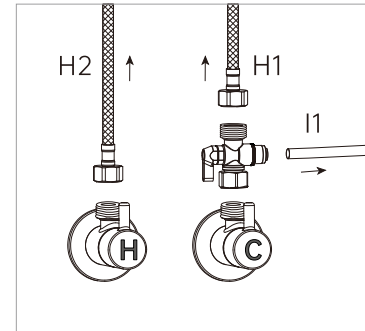

3. Connect the red flexible tail (H2) onto the angle valve from hot water supply side.
The blue flexible tail (H1) is connected to the three-way transfer valve and installed on the cold water Angle valve.

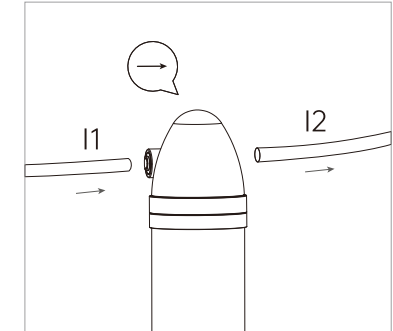

4. PE tube (I1) is connected to three-way transfer valve and filter.
PE tube (I2) is connected to filter.
Please pay attention to the water arrow.

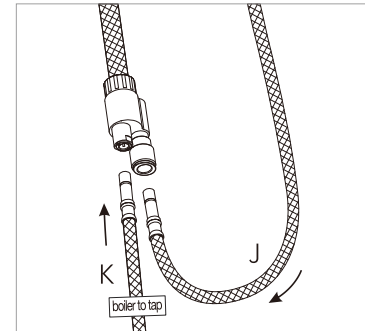

5. Install the quick installation woven pipes (K) and (J) respectively onto the joints of the pull-out tubes.

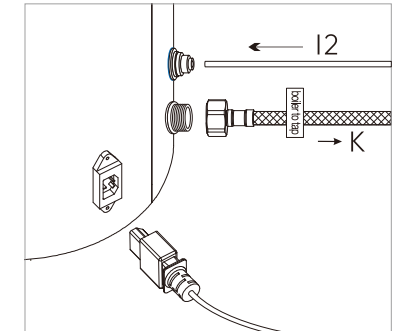

6. Install the quick installation woven pipe (K) onto the hot water valve of the heating tank.
The PE tube (I2) onto the cold water valve.
The signal line connector connecting tap to heating tank.
Plug in and press the power button and set the temperature.

7

How To Use Your 4 in 1 Boiling Water Tap

(i) **For filtered hot water**, press the left handle button.
Keep the button pressed and rotate the handle forwards for instant hot water.

(ii) **For filtered cold water**, press the left handle button.
Keep the button pressed and rotate the handle backwards for filtered cold water.

(iii) **For mixed water**, pull the large lever backwards for mains hot water and forwards for mains cold water dispensing.

Regulation Requirements

It is important to ensure that the water supply to your tap is connected in accordance with the water regulation requirements, plumbing code and good plumbing practice.

It is good practice that the supply of hot and cold water to the tap are equal (balanced) pressure in order to provide a consistent flow. Water supply should be from a common source, either mains or tank fed. If the water supply is not equal pressure then a Non Return Valve (check valve) should be fitted on the hot inlet.

Water Supply Pressures

This tap has been designed to function under the following conditions:
+ Minimum supply pressure for cold water is 1.5 bar Maximum supply pressure 5 bar (although we only recommend a Maximum supply pressure of 3.0 bar)

Important - Care And Maintenance Of The Tap

Only clean the tap with a soft cloth, warm water and a mild detergent solution. Rinse the tap clean thoroughly afterwards with water. Do not use any abrasive or harsh chemical products, otherwise this will invalidate your guarantee.

These instructions are only intended as a guide, if there is any doubt then contact a certified plumber or service agent and avoid using the Instant Hot Water System until it has been checked.

Boiling Water Tank

Operation Instructions - Instant Hot Water Tank

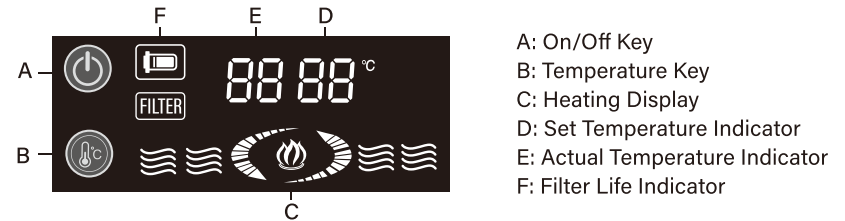

To switch the instant hot water heater on or off

Touch the "On/Off" key (A) once to switch the water heater on.
Touch the "On/Off" key (A) once again at any time to switch the water heater off.

To set the water temperature

Touch the "Temperature" key (B) several times to scroll through the available temperatures 75°C/85°C/90°C/95°C/98°C. Once you had decided the desired temperature, leave it stands and the indicator will be flashing for 3 times. The temperature is now set for the desired temperature.

Filter Replacement Indicator and Schedule

The boiler is equipped with a filter change notification system. When it's time to replace the filter, a specific display light will activate as a reminder. It is essential to adhere to this schedule to maintain the optimal functioning of your boiler:

Standard Replacement Interval: Filters should be replaced every 6 months. Failure to replace the filter within this timeframe may lead to damage to your boiler. Please be aware that damage caused by not replacing the filter as recommended is not covered under the warranty.

Special Consideration for Hard Water Areas: If you reside in an area with extremely hard water, the filter may require replacement every 3 months. In such cases, the filter change display light will activate earlier to remind you of the need for more frequent replacement.

Note

- > At all times, the "Actual temperature" indicator (E) shows the actual temperature of the water in the reservoir/heater unit.
- > When the water is heating the "Heating" indicator (C) will illuminate and the "Heating" display (C) will animate.
- > When the water in the reservoir/heater unit is at the set temperature the "Hot" indicator (C) will illuminate and the "Heating" display (C) will illuminate constantly

Trouble Shooting

Below is a list of some of the possible malfunctions. If the problem cannot be resolved as described, please contact Hanstrom.

PROBLEM	POSSIBLE CAUSES	WHAT TO DO
"Set Temperature" indicator flashed "E3".	Insufficient water in the tank.	Prime the installation as described in the installation instructions.
Water and steam is spitting from the instant hot water tap spout.	Unit is boiling.	Turn the instant hot water tap handle on and release the water. Adjust the water temperature on the display to a lower setting.
Water is not hot.	The electronic instant hot water appliance is unplugged. There has been a power cut. The electronic unit has not been powered up.	Make sure the electronic instant hot water appliance is plugged in and connected to an earthed electric outlet. Make sure that the circuit breaker and fuses are working correctly. Reset the temperature the press the confirm key. Turn on the power and touch the on/off button, then set the required temperature and confirm the boiler heats up.
Water is not hot.	Water temperature setting on display panel is set too high.	Set the temperature to the required level and confirm the boiler heats up.
Water drips from the 4 in 1 instant boiling water tap spout.	The expansion chamber isn't draining the system correctly due to very small draw off of water. The spout is blocked.	Draw off 0.5L of water to clear and prime the system. Avoid drawing off less than 150ml of water at all time. Remove and clean the aerator on the tap.
Slow flow from the spout.	The water filter may be clogged from impurities in the inlet mains water.	The water filter must be changed every 6 months. Failure to do this will void the guarantee.
Water does not flow immediately.	The 4 in 1 Instant boiling tap is designed for non-pressurised operation so there will be slight delay before the near boiling water starts to flow.	This is not a fault. Note that after a large volume of water has been drawn off there maybe a slightly longer delay in the water appearing from the tap spout.
No water flows.	Water valves have been turned off. Inlet pipes have become twisted or blocked.	Turn on all the water valves. Ensure the pipes are not twisted or kinked and restricting flow. Remove and clean the aerator.

Specifications

*If pressure is above 0.5 MPa (5 bar) then a pressure reducing valve is required

Supply	220v-240v ~ 50Hz
Power	1.5 kW
IP Rating	X4
Tank Capacity	2.4 litres
Immediate Draw Off	1.7 litres
Minimum Supply Pressure	0.1 MPa (1 bar)
Maximum Supply Pressure	0.5 MPa* (5 bar)
Hot and Cold Connections	1/2" BSP
Approvals	RCM, CE



INFORMATION FOR CORRECT DISPOSAL OF THE PRODUCT IN ACCORDANCE WITH THE EUROPEAN DIRECTIVE 2002/96/E.

At the end of its working life this equipment must not be disposed of as household waste. It must be taken to a local authority waste collection centre or to a dealer providing this service. Disposing of electrical and electronic equipment separately enables its components to be recovered and recycled to obtain significant savings in energy and resources. In order to underline the duty to dispose of this equipment separately, the product is marked with a crossed out dustbin.

Guarantee

The boiler is covered by a standard parts or replacement warranty for a period of 12 months from the date of purchase. We offer 24 months warranty for the tap itself. If there is a manufacturing defect within the warranty period we will send spare parts, repair and return the unit or, at our discretion, supply a replacement product. Incorrect installation, frost damage, the consequences of limescale deposits or failure to follow correct operating and maintenance instructions are excluded. Consequential costs such as labour charges or damage to fittings and surroundings are expressly excluded.

Contact Us

If you experience a problem with this product you should first contact our service department before taking any further action. Experience has shown that issues can often be resolved without the need to return or uninstall the product.

☎ 01924 730 525 ✉ sales@hanstrom.com